

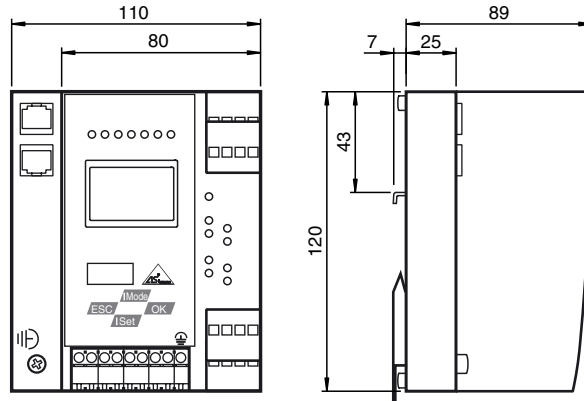

Dimensions

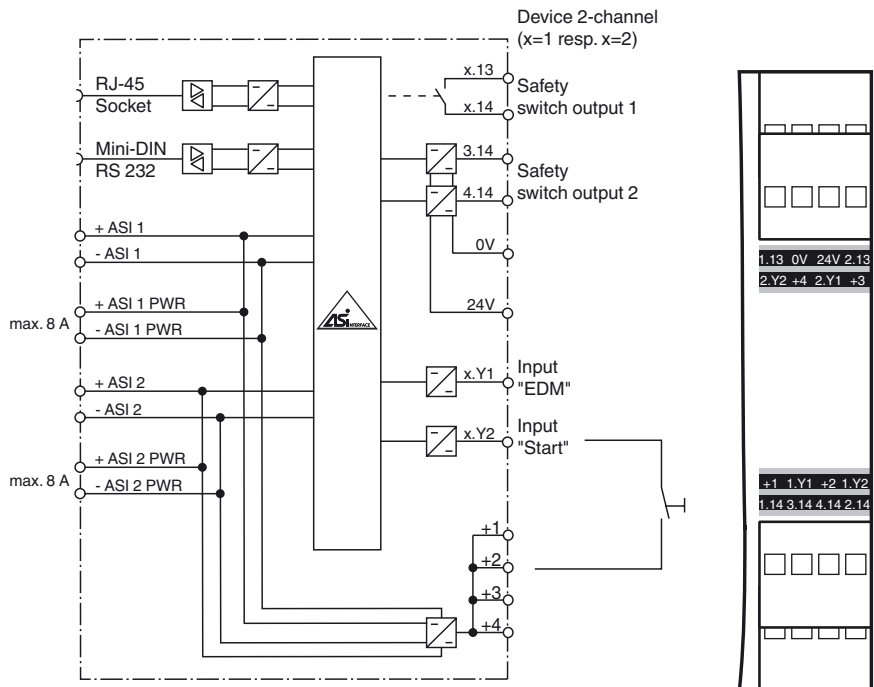

Electrical connection



Model number

VBG-ENX-K30-DMD-S16

EtherNet/IP + Modbus TCP Gateway with integrated safety monitor, double master for 2 AS-Interface networks

Features

- Gateway and safety monitor in one housing
- Gateway compliant with AS-Interface specification 3.0
- Connection to Ethernet Modbus TCP/IP
- AS-Interface safety monitor with extended range of functions
- Certified up to SIL 3 according to IEC 61508 and EN 62061 and up to PL_e according to EN 13849
- Memory card for configuration data
- 2 AS-Interface networks
- 2 safe output relays and 2 safe electronic outputs
- Integrated switch allows line topology
- DLR technology supports ring topology

Indicating / Operating means

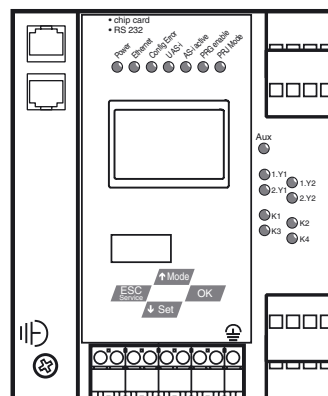

Release date: 2017-05-17 12:18 Date of issue: 2017-05-17 223636_eng.xml

Technical data**General specifications**

AS-Interface specification	V3.0
PLC-Functionality	activateable
Duplicate address detection	from AS-Interface slaves
Earth fault detection	EFD integrated
EMC monitoring	integrated
Diagnostics function	Extended function via display
Switch-on delay	< 10 s
Response delay	< 40 ms
UL File Number	E223772 only from low voltage, limited energy source (SELV or PELV) or listed Class 2 source

Functional safety related parameters

Safety Integrity Level (SIL)	SIL 3
Performance level (PL)	PL e
MTTF _d	200 a
B _{10d}	2 E+7

Indicators/operating means

Display	Illuminated graphical LC display for addressing and error messages
LED ETHERNET	ethernet active; LED green
LED AS-i ACTIVE	AS-Interface operation normal; LED green
LED CONFIG ERR	configuration error; LED red
LED PRG ENABLE	autom. programming; LED green
LED POWER	voltage ON; LED green
LED PRJ MODE	projecting mode active; LED yellow
LED U AS-i	AS-Interface voltage; LED green
LED AUX	ext. auxiliary voltage U _{AUX} ; LED green
LED EDM/Start	External device monitoring circuit inputs closed, 4x yellow LEDs
LED output circuit	Output circuit closed; 4 x green LEDs
Button	4

Electrical specifications

Insulation voltage	U _i	≥ 500 V
Rated operating voltage	U _e	26.5 ... 31.6 V from AS-Interface; Output K3 and K4 24 V _{DC}
Rated operating current	I _e	≤ 300 mA off AS interface network 1 ≤ 300 mA off AS interface network 2 ≤ 370 mA in total

Interface 1

Interface type	2 x RJ-45
Protocol	EtherNet/IP + MODBUS TCP/IP acc. to IEEE 802.3 supports device level ring protocol DLR
Transfer rate	10 MBit/s / 100 MBit/s, Automatic baud rate detection

Interface 2

Interface type	RS 232, serial Diagnostic Interface
Transfer rate	19,2 kBit/s

Interface 3

Interface type	Chip card slot
----------------	----------------

Input

Number/Type	4 EDM/Start inputs: EDM: Inputs for the external device monitoring circuits Start: start inputs: Static switching current 4 mA at 24 V, dynamic 30 mA at 24 V (T=100 μs)
-------------	---

Output

Safety output	max. contact load: Output circuits 1 and 2: 2 potential-free contacts, 3 A _{DC-13} at 30 V _{DC} . 3 A _{AC-15} at 30 V _{AC} . Output circuits 3 and 4: 2 PNP transistor outputs 0.5 A _{DC-13} at 30 V _{DC}
---------------	---

Connection

Ethernet	RJ-45
AS-Interface	spring terminals, removable

Ambient conditions

Ambient temperature	0 ... 55 °C (32 ... 131 °F)
Storage temperature	-25 ... 85 °C (-13 ... 185 °F)

Mechanical specifications

Degree of protection	IP20
Mass	800 g
Construction type	Low profile housing, Stainless steel

Compliance with standards and directives

Directive conformity	
EMC Directive 2004/108/EC	EN 61000-6-2:2005, EN 61000-6-4:2007
Standard conformity	
Electromagnetic compatibility	EN 61000-6-2:2005, EN 61000-6-4:2007

Function

The VBG-ENX-K30-DMD-S16 is an Ethernet/IP+Modbus TCP gateway with an integrated safety monitor and a double master according to AS-Interface specification 3.0 with a degree of protection IP20.

The device is a gateway with full functionality combined with a safety monitor. The gateway connects an AS-Interface system to a higher-level Ethernet or Modbus protocol. It acts as a master for the AS-Interface segment and as a slave for Ethernet / Modbus. During cyclic data exchange, the digital data of an AS-Interface segment is transferred. Analog values as well as the complete command set of the new AS-Interface specification are transferred via Ethernet / Modbus using a command interface.

The gateway has four inputs and four outputs. The four inputs are used either for extended EDM device monitoring or as start inputs. Two sets of two outputs act as relay outputs and switch output circuits 1 and 2 and, as semiconductor outputs, output circuits 3 and 4. The K30 model is particularly suitable for installation in a control cabinet.

Configuration of the device can be performed using switches. Seven LED located on the front panel indicate the current status of the AS-Interface segment. One LED shows the power supply via AUX. A further eight LEDs indicate the status of the inputs and outputs.

With the graphical display, the commissioning of the AS-Interface circuits and testing of the connected peripherals can take place completely separately from the commissioning of the higher-level network and the programming. With the 4 switches, all functions can be controlled and visualized on the display.

The device has a card slot for a memory card for the storage of configuration data.

An integrated Switch and 2 RJ-45 sockets allow the design of a line topology without the use of an external Switch.

The device level ring protocol DLR increases the reliability of a ring topology at the device level, thus optimizing the machine running times.

An integrated webserver allows to administrate the device and The AS-interface network without additional hard and/or software via a browser interface.

The redundant power supply guarantees that the double master remains in function and is diagnosticable, when a failure of a power supply unit in one of the two AS-interfaces circles occurs. Also communication with the superior field bus is not disturbed by the failure of a power supply.

Accessories**VAZ-SW-SIMON+**

Software for configuration of K30 Master Monitors/K31 and KE4 Safety Monitors

USB-0,8M-PVC ABG-SUBD9

Interface converter USB/RS 232

AS-Interface	EN 50295:1999
Degree of protection	EN 60529:2000
Shock and impact resistance	EN 61131-2:2004
Standards	EN 61000-6-2:2005, EN 61000-6-4:2007 EN 954-1:1996 (up to Kategorie 4), IEC 61508:2001 and EN 62061:2005 (up to SIL3) EN 13849:2008 (PL e)

Approvals and certificates

UL approval	An isolated source with a secondary open circuit voltage of $\leq 30 V_{DC}$ with a 3 A maximum over current protection. Over current protection is not required when a Class 2 source is employed. UL mark does not provide UL certification for any functional safety rating or aspects of the device.
-------------	---

Notes

In an AS-Interface network only one device can be operated earth fault detection. If there are many devices in an AS-Interface network, this can lead to the earth fault monitoring response threshold becoming less sensitive.

Release date: 2017-05-17 12:18 Date of issue: 2017-05-17 223636_eng.xml

Refer to "General Notes Relating to Pepperl+Fuchs Product Information".

Pepperl+Fuchs Group
www.pepperl-fuchs.com

USA: +1 330 486 0001
fa-info@us.pepperl-fuchs.com

Germany: +49 621 776 4411
fa-info@de.pepperl-fuchs.com

Singapore: +65 6779 9091
fa-info@sg.pepperl-fuchs.com