

Hygienic 400

Safety valve made of stainless steel, angle type, with stainless steel spring

→ **Series Hygienic 400**



■ MATERIAL



■ SPECIFICATION



■ SUITABLE FOR

Liquids	neutral and non-neutral	
Air, gases and vapours	neutral and non-neutral	
Steam		

■ EXAMPLES OF USE

For the protection of:

- processes, plants and containers in the food and pharmaceutical industry for air, neutral and non-neutral vapours and gases, steam and liquids taking into account the operation- and plant-specific regulations and making use of the suitable valve version and sealing material.

- Food industry
- Breweries and beverage industry
- Pharmaceutical industry
- Cosmetic industry
- Medical technology
- Clean Service applications

■ FEATURES

- Smooth and faultless surface finish optimized for cleaning process
- Minimal dead space in inlet area and no gaps in the valve
- Exposed and rinsed o-ring seals
- Shape of valve body avoids forming of puddles in the valve
- Adjustable and settable during operation
- Possible to carry-out CIP/SIP by lifting the disc from the seat
- Gap-free installation of seals
- Surface roughness in the primary area Ra < 0.75µm
- Optional: electropolished and/or mechanically polished
- Moulded diaphragm for separating the product space from the springhousing
- Dead space ratio L/D ~ 1,5

For explanation see chapter 1.1 General information on the hygienic valves. Definition of surface quality and options according to Chapter 1.1 Table V-301.

■ APPROVALS

TÜV-Type test approval 2062	D/G, F, F/K/S
EU type examination	S/G, L, F/K/S
TSG ZF001-2006	S/G, L, F/K/S
KGS	G
TR ZU 032/2013 - TR ZU 010/2011	S/G, L, F/K/S
Requirements	
DIN EN ISO 4126-1	TRD 421
PED 2014/68/EU	AD 2000 Data sheet A2
TRB 801 No. 22 and 23	KGS AA 319
Additional hygienic requirements	
EG No. 852/2004	GS-NG 2 and 5
DIN EN 1672-2	EHEDG Aseptik
9. GPSGV	
Classification society	
DNV	DNV
Bureau Veritas	BV
Russian Maritime Register of Shipping	RS

■ MATERIALS

Component	Material	DIN EN	ASME
Body	Stainless steel	1.4435	316 L
Inner parts, wetted	Stainless steel	1.4435	316 L
Upper section, other inner parts	Stainless steel	1.4404	316 L
Spring	Stainless steel	1.4310	302
Bellows	Stainless steel	1.4571	316 Ti

b	Standard with bellows	for neutral and non-neutral media and/or counter pressure up to 4 bar. Spring, moving parts and the environment are protected from being affected by the medium.
----------	-----------------------	---

Parts which are difficult to clean in the guide, the spring housing and the spindle / disc combination are protected against soiling by stainless steel bellows

■ MEDIUM

GF	gaseous and liquid	Air, vapours, gases, liquids and - depending on safety valve version and seal - also for steam
-----------	--------------------	--

■ TYPE OF LIFTING MECHANISM

K	Standard with twist-type lifting mechanism
----------	--

■ AVAILABLE NOMINAL DIAMETERS AND CONNECTION SIZES

Nominal diameter		20									
Connection type		Clamp connection						Threaded ferrule connection			
		DIN 11864-3 / DIN 11853-3			DIN 32676			DIN 11864-1 / DIN 11853-1		DIN 11851	
Inlet		DN 20	DN 25	DN 32	DN 20	DN 25	DN 32	DN 20	DN 25	DN 20	DN 25
Outlet	DN 25	■	■	■	■	■	■	■	■	■	■
	DN 32	■	■	■	■	■	■				

■ TYPE OF CONNECTION INLET / OUTLET

KLSDIN / KLS DIN	Standard	Clamp connection / Clamp connection	DIN 32676 -A/ DIN 32676-A	Pipe Standard DIN 11850 / 11866
GSDIN / GSDIN		Threaded ferrule connection / Threaded ferrule connection	DIN 11851 / DIN 11851	Pipe Standard DIN 11850 / 11866
		Aseptic collar clamp connection / Aseptic collar clamp connection	DIN 11864-3 / DIN 11864-3 DIN 11853-3 / DIN 11853-3	Pipe Standard DIN 11850 / 11866
		Aseptic-Threaded ferrule connection A/ Aseptic-Threaded ferrule connection A	DIN 11864-1 / DIN 11864-1 DIN 11853-1 / DIN 11853-1	Pipe Standard DIN 11850 / 11866

Other connection types possible on request.

■ SEALS

FKM	Fluorcarbon	Elastomere moulded seal	FDA, USP, 3-A, ADI-free	-20°C to +200°C
EPDM	Ethylene propylene diene	Elastomere moulded seal	FDA	-40°C to +170°C

■ NOMINAL DIAMETERS, CONNECTIONS, INSTALLATION DIMENSIONS

Series Hygienic 400: Connection, installation dimensions, ranges of adjustment							
Nominal diameter	DN	20			20		
Connection		Aseptic collar clamp connection DIN 11864-3 / DIN 11853-1 Clamp connection DIN 32676			Aseptic-Threaded ferrule connection A DIN 11864-1 / DIN 11853-1 Threaded ferrule connection DIN 11851		
Inlet	DN	20	25	32	20	25	
	G	-	-	-	20 (Rd 44 x 1/6")	25 (Rd 52 x 1/6")	
Outlet	DN1	25, 32	25, 32	32	25	25	
	G1	-	-	-	25 (Rd 52 x 1/6")	25 (Rd 52 x 1/6")	
Installation dimensions in mm	L	-	-	-	75	75	
	L1	65	65	65	-	-	
	H	145	145	145	145	145	
	h	29	29	29	-	-	
	h1	-	-	-	40	40	
	D	34	50,5	50,5	-	-	
	D1	50,5	50,5	50,5	-	-	
	do	18	18	18	18	18	
	Weight	kg	1,3	1,3	1,3	1,4	1,4
	Range of adjustment	bar	0,4-16	0,4-16	0,4-16	0,4-16	0,4-16

■ MAIN DIMENSIONS, INSTALLATION DIMENSIONS

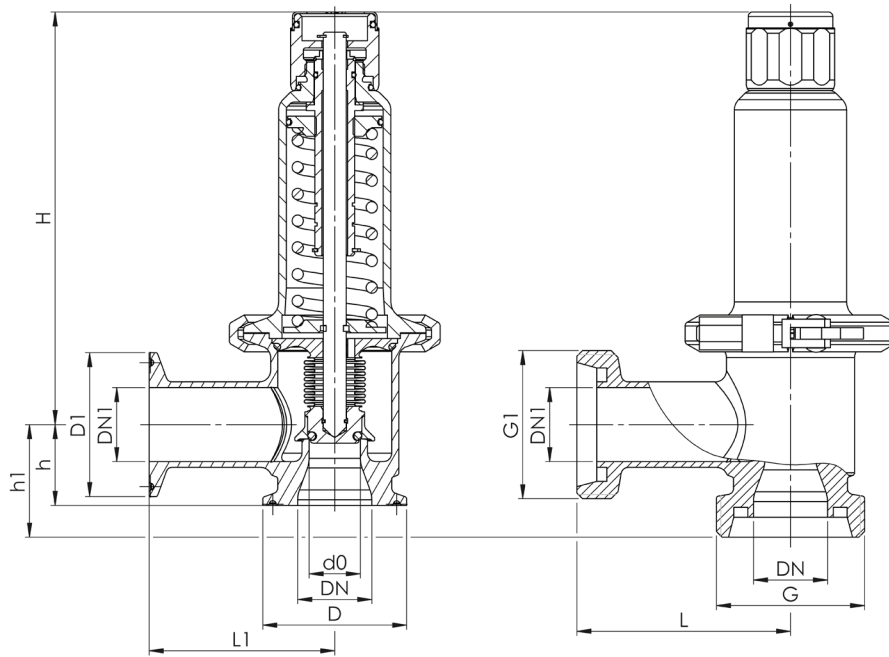

Series	Valve version	Medium	Lifting device	Nominal diameter DN	Connection type		Connection type		Seal	Options	Set pressure
					Inlet	Outlet	Inlet	Outlet			
400	b	GF	K	20	GSDIN	GSDIN	25	25	FKM	P09	2,5
400	b	GF	K	20	KLSDIN	KLSDIN	25	25	EPDM	P07	3,2
400	b	GF	K	20							
400	b	GF	K	20							
400	b	GF	K	20							

■ PROPERTIES

DEFINITION OF SURFACE QUALITY AND OPTIONS ACCORDING TO CHAPTER 1.1 TABLE V-301

P01	Oil- and grease-free production	<input type="checkbox"/>	<input type="checkbox"/>
P05	Quality of surfaces in contact with media in inlet Ra ≤ 0,375	<input type="checkbox"/>	<input type="checkbox"/>
P07	Electropolished surfaces	<input type="checkbox"/>	<input type="checkbox"/>
P09	Surfaces mechanically and electropolished	<input type="checkbox"/>	<input type="checkbox"/>

■ CERTIFICATES / APPROVALS

C01	Factory certificate acc. DIN EN 10204 2.2 (WKZ 2.2)	<input type="checkbox"/>	C06	ATEX evaluation acc. to 2014/34/EU	<input type="checkbox"/>
C02	Test certificate acc. DIN EN 10204 3.1 (WPZ 3.1)	<input type="checkbox"/>	C07	SIL evaluation relating to IEC 61508-2	<input type="checkbox"/>
C03	Material test certificate acc. DIN EN 10204 3.1 (MPZ 3.1) (pressure retaining part)	<input type="checkbox"/>	C09	Seat tightness test with helium, leak detection method under vacuum incl. Factory Inspection Certificate 3.1 acc. to DIN EN 10204	<input type="checkbox"/>
C04	TÜV/DEKRA individual inspection acc. EN 10204 3.2 (TÜV/DEKRA-APZ)	<input type="checkbox"/>	C10	Certificate of oil- and grease free production	<input type="checkbox"/>
C05	Sealing material Manufacturer certification (FDA, USP 3, 3-A,...), Please indicate description of certificate:	<input type="checkbox"/>			<input type="checkbox"/>

■ ADMISSIONS / ACCREDITATIONS

AA1	EC Type examination acc. to Directive 2014/68/EU	<input type="checkbox"/>	AK1	Det Norske Veritas (DNV) type approval	<input type="checkbox"/>
AA2	TÜV component test acc. to VdTÜV specification sheet SV 100	<input type="checkbox"/>	AK2	Lloyd's Register (LR) type approval	<input type="checkbox"/>
AA4	EAC - certificate/declaration with passport for the valve and laser marking of the valve	<input type="checkbox"/>	AK3	American Bureau of Shipping (ABS) type approval	<input type="checkbox"/>
AA5	Manufacture License of Special Equipment People's Republic of China (ML)	<input type="checkbox"/>	AK4	Bureau Veritas (BV) type approval	<input type="checkbox"/>
	<input type="checkbox"/>		AK5	Russian Maritime Register of Shipping (RMRS) type approval	<input type="checkbox"/>
	<input type="checkbox"/>		AK6	Registro Italiano Navale (RINA) type approval	<input type="checkbox"/>
	<input type="checkbox"/>		AL	Individual inspection by notified body inspector – (body to be indicated):	<input type="checkbox"/>

■ ENQUIRY

Copy and send to: order@goetze-armaturen.de.

Order form easily to be found online under the section for each series.

Series Hygienic 400: Blowing-off rates at 10% above set pressure				
Nominal diameter DN		20		
Set pressure bar	I	II	III	
0,5	127	96	3,1	
1	189	151	4,5	
1,5	257	204	6,7	
2	332	262	7,7	
2,5	390	305	8,6	
Air I	3	349	9,4	
Nm ³ /h	3,5	392	10,2	
	4	435	10,9	
Steam II	4,5	478	11,5	
kg/h	5	521	12,2	
	5,5	564	14,0	
Water III	6	608	14,6	
m ³ /h	6,5	650	15,2	
	7	692	15,8	
	7,5	735	16,4	
	8	777	16,9	
	8,5	820	17,4	
	9	862	17,9	
	9,5	905	18,4	
	10	947	18,9	
	11	1031	19,8	
	12	1115	20,7	
	13	1199	21,6	
	14	1284	23,4	
	15	1368	24,2	
	16	1453	25,0	