



Equipment for Reverse Osmosis Desalination Systems

Pumps • Energy Recovery Devices • Valves • Seals



Experience In Motion



Reduce your total cost with our reverse osmosis equipment

As global demand for clean water continues to accelerate, safe and reliable desalination solutions are increasingly important to many communities. The energy-efficient and scalable design of the seawater reverse osmosis (SWRO) process makes it the leading choice for municipal and commercial water supply.

With more than a half-century of experience providing key products incorporating the latest technologies and support services, Flowserve offers you trusted pumps and energy recovery solutions that are considered among the most efficient and reliable in the world.

Fully integrated systems and services

Unlike most manufacturers, Flowserve has the ability to provide you with complete, fully integrated flow-control solutions. In addition, you'll enjoy a wide range of benefits that will keep your total cost of ownership low, including:

- Unparalleled design and operation expertise that maximizes your efficiency
- A robust worldwide service network, with local support of parts, repairs and service through nearly 200 global Quick Response Centers

- Equipment and system optimization
- Performance and availability guaranteed by condition monitoring and fixed-fee maintenance contracts
- Customized aftermarket solutions, including service, maintenance and upgrades
- A single point of contact and accountability for all major equipment, including pumps, energy recovery devices (ERDs), valves and mechanical seals
- Educational services that train your personnel in the selection, operation and maintenance of pumps, energy recovery devices, seals and valves

By bringing together industry-leading pumps and valves, high-efficiency ERDs, unmatched materials expertise and desalination-specific application knowledge, Flowserve is a single-source provider of complete, integrated flow-control systems for desalination plants around the world.

Experience that counts

Flowserve understands the challenges you face, from energy consumption and high-pressure pumps to the other obstacles faced by every business model in the industry. That's why Flowserve equipment is installed in some of the biggest desalination plants in the world and more than two-thirds of mega SWRO projects use Flowserve pumps and ERDs. We've been a leader in desalination since it was commercialized on a large scale, and have partnered with some of the world's largest desalination engineering, procurement and commissioning (EPC) contractors, developers and end users to build plants using thermal and membrane technologies.

Whether your site is a government-backed fixed EPC project, a privately financed build-own operate (BOO), or a build-own-operate-transfer (BOOT) venture, dedicated Flowserve desalination experts and project managers are available to help you optimize your operation.

Make the most of your energy investment

While advances in membrane and energy recovery technologies are making SWRO and brackish water reverse osmosis (BWRO) more economical, energy consumption remains the biggest operating cost of reverse osmosis (RO) desalination.

Optimize efficiency

Since high-pressure pumps and other equipment in RO plants can consume a lot of power, we design optimal efficiency into every one of our systems. Our high-pressure membrane feed pumps and ERDs — including Calder® DWEER™ isobaric devices and Calder ERT energy recovery turbines — feature optimized hydraulics and advanced materials to keep your operating costs low and your plant running profitably. You'll also have access to detailed systems knowledge, along with a full menu of technical support services, wherever and whenever you need them, to ensure your plant's availability goals are met.

Streamline execution

For new projects or major upgrades, dedicated global project managers and engineering experts will help you streamline execution. You'll get a total-solution approach, focused on creating the most efficient and technologically advanced systems. Flowserve works with your teams to select equipment, maximize overall efficiency, and optimize plant layout. We'll also work tirelessly to ensure installation and commissioning meet your requirements and schedules.

Manage risks

For existing operations, Flowserve offers aftermarket services and supporting infrastructure to help you manage risks. Turnkey maintenance contracts guarantee best efficiencies of key equipment, while monitoring and preventative maintenance service plans make sure your plant availability and throughput goals are achieved.

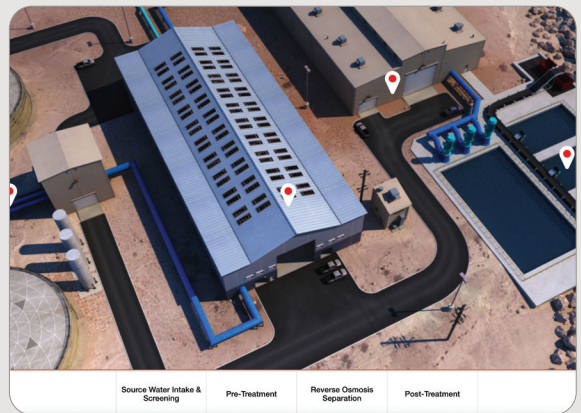

Explore Flowserve VirtualPlant

Flowserve VirtualPlant offers an innovative way for you to explore Flowserve products and capabilities for the desalination industry. A 3D model of a reverse osmosis plant makes it easy to see which products are used in key processes. The information within VirtualPlant is based on actual use cases, so you can be confident that all product recommendations are based on proven customer scenarios and real-world conditions.

SWRO products and capabilities

The simple design, lower energy consumption and smaller footprint of the reverse osmosis process have made this technology the choice for most municipal, industrial and commercial desalination projects. Flowserve enhances these advantages for your business by delivering capabilities that address major pump, energy recovery, seal and valve requirements.

Pumps

Desalination applications for pumps run the gamut, from source water intake and pressure boosting to various feed and chemical applications. Key configurations and pumping solutions supported by Flowserve include:

- Vertical wet- and dry-pit configurations (VTP, SUBM, VCT, LNNV)
- Between bearings, single-stage (LNN, LR, DVSH)
- Vertical inline process pumps (LNNV)
- Horizontal, overhung process pumps (HPX, HHPX, HPX-H, Mark 3™, CBT, ZLN, DS)
- Between bearings, multistage (DMX, CSX, WDX, MSC)

Energy recovery devices

Energy is generally the biggest cost driver in any SWRO desalination facility, making energy recovery critical to your success. Flowserve is a world leader in the manufacture and supply of the most efficient energy recovery devices for the SWRO desalination process. Through its Calder brand, Flowserve has more than 30 years of experience and has recovered more than 750 MW of energy.

Flowserve offers the following leading technologies for energy recovery:

- Dual Work Exchanger Energy Recovery (DWEER) — an isobaric energy recovery device capable of recovering up to 98% of the energy in the brine waste stream
- Energy Recovery Turbines — capable of recovering as much as 90% of the hydraulic energy in the brine waste stream

In addition to minimizing your current power usage, both of these technologies help minimize the impact of future energy cost increases.

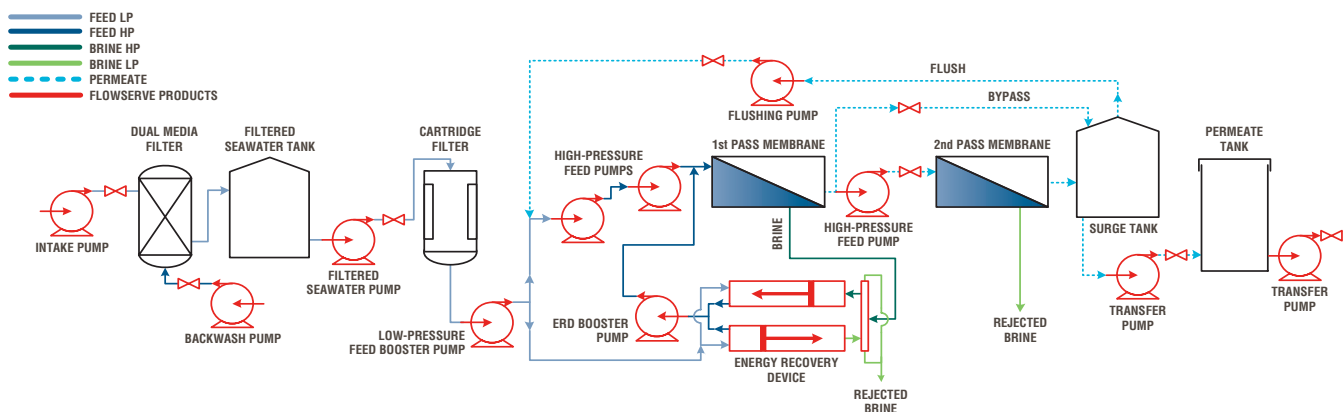

Mechanical seals for SWRO

Mechanical seals are integral to the range of pumps used in SWRO desalination plants, providing maximum reliability with minimal downtime. Unmatched expertise in metallurgy, combined with the application of sophisticated mechanical seal technology in the toughest applications, allow Flowserve to help you extend the mean time between failure (MTBF) of your critical equipment.

Valves and actuators for SWRO

Desalination processes, particularly SWRO systems, require numerous valves capable of handling large volumes of water at high pressures. These valves must also be made of materials capable of resisting corrosion from chloride-rich water and commonly used chemicals. Flowserve offers a complete range of valves and actuators to suit diverse desalination applications.

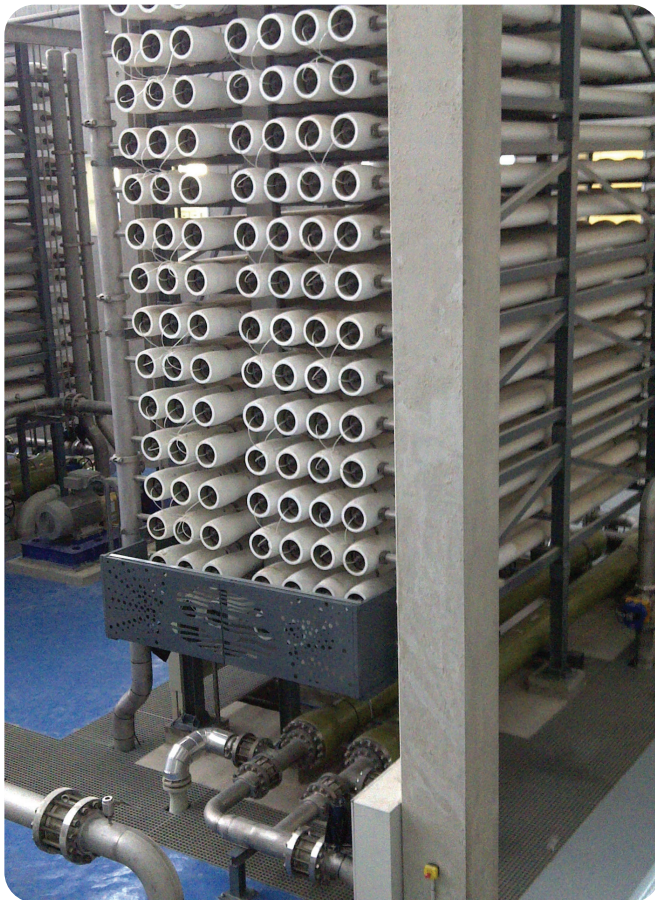

SWRO membrane train with DWEER energy recovery device installed in Spain

Tough construction ensures corrosive-resistant performance

All Flowserve equipment that comes into contact with seawater or brine is delivered in super duplex stainless steel or non-metallic, capable of withstanding seawater or even brine with increased total dissolved solids (TDS).

For high-pressure and ERD booster pumps, Flowserve can supply equipment in Flowserve Alloy, a special austenitic stainless steel. With decades of proven stability in desalination applications, Flowserve Alloy is ideal for applications where high temperatures and salinity make for very aggressive fluids.

Upgrade options for existing installations

ERDs, pumps, membranes and other important features have seen continuous improvement over the last few decades with the development of new technologies. By integrating these innovations into your existing facility, Flowserve can deliver efficiency and reliability improvements that enhance your business in four key ways:

- Increased plant efficiency
- Increased plant production
- Reduced plant maintenance
- Increased availability

These benefits can be achieved by overhauling existing equipment with additional reliability features, upgraded hydraulics or other capabilities. In addition, existing ERDs can be replaced with newer technologies that improve both your efficiency and product capacity.



Pumps for SWRO

Source water intake pumps

SWRO source water intake requires pumps that are corrosion-resistant and have the versatility to fit various intake methods. Flowserve offers several highly efficient vertical and horizontal pump models with proven performance to suit your application's needs.

Flowserve vertical source water intake pumps offer broad capacity ranges to maximize system efficiency while minimizing initial cost. Flowserve also offers horizontal pumps for dry-pit installation or space-saving vertical configurations which provide the same premium efficiency with a reduced footprint.

Configurations: Wet-pit and dry-pit

Materials: Duplex and super duplex stainless steels

Models: LNN, LNNV, VCT, VTP, SUBM

Flows: to 181,700 m³/h (800,000 gpm)

Heads: to 700 m (2,300 ft)

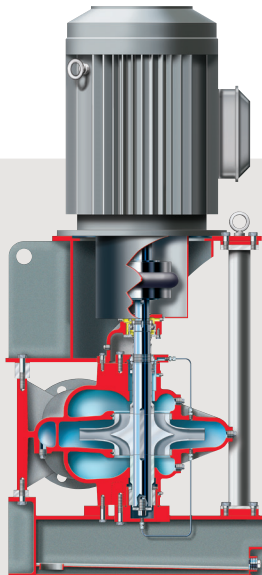

LNNV

High efficiency and low
NPSH requirements

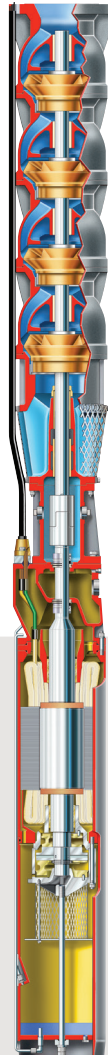

Byron Jackson® SUBM

Rugged, reliable and long-lasting

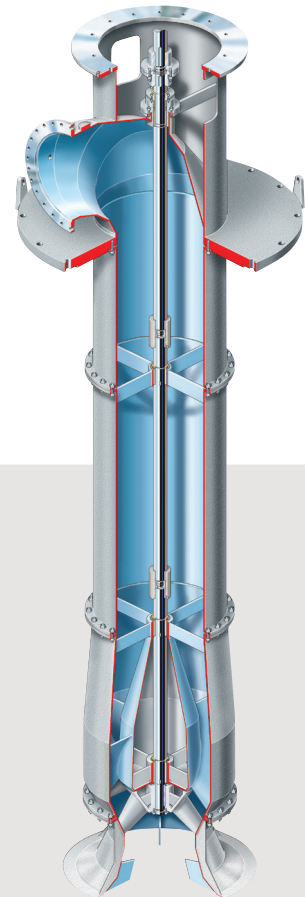

VCT

Outstanding efficiency
and long service life

Auxiliary pumps

Flowserve can provide pumping solutions for virtually all desalination plant support services, including the pretreatment process, product water supply and clean-in-place (CIP). Pumps are available in various configurations and materials to meet the precise needs of your site.

- Filtered seawater
- Low-pressure feed booster
- High-pressure feed booster
- Product services
- Potable water
- Backwash
- Flushing pumps

Configurations: Single-stage, end suction or between bearings

Materials: 316 stainless steel, duplex or super duplex stainless steels; non-metallic materials

Models: Mark 3, LNN, CBT, ZLN, HPX, DS-RO

Flows: to 30,000 m³/h (132,000 gpm)

Heads: to 350 m (1,100 ft)

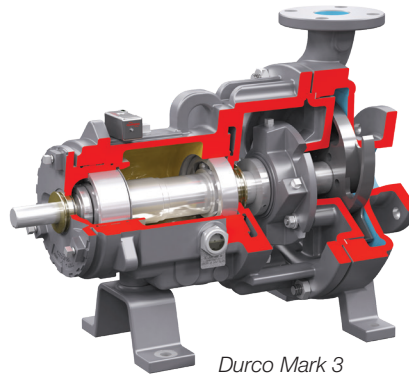

Durco Mark 3
Unmatched reliability and outstanding performance

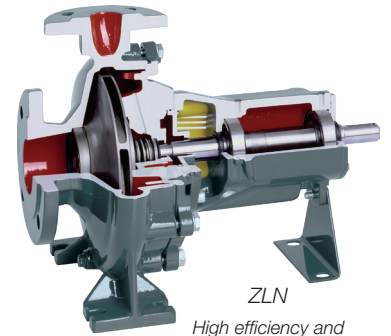

ZLN
High efficiency and extended reliability

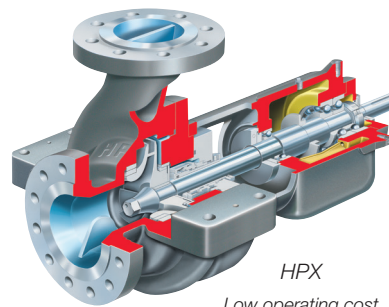

HPX
Low operating cost and longer service life

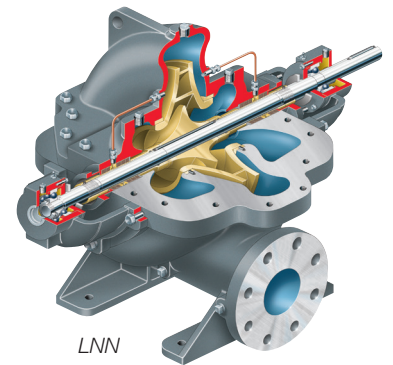

LNN
High efficiency and low NPSH requirements



CBT
High capacity and simplified maintenance

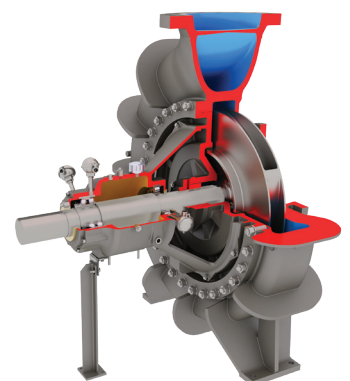

DS-RO
High efficiency and increased uptime

High-pressure membrane feed

All Flowserve high-efficiency membrane feed pumps utilize the latest technology and are designed using computational fluid dynamics to provide the best system performance. These critical pumps are manufactured in corrosion-resistant materials to ensure long performance life without degradation. Horizontal split case (DMX, DVSH) or ring section (CSX, WDX, MSC) models are available.

Configurations: Multistage or single-stage, between bearings

Materials: Duplex or super duplex stainless steels; Alloy 885

Models: DMX-RO, CSX, WDX, MSC, DVSH-RO

Flows: 7,000 m³/h (30,820 gpm)

Heads: to 1,000 m (3,281 ft)

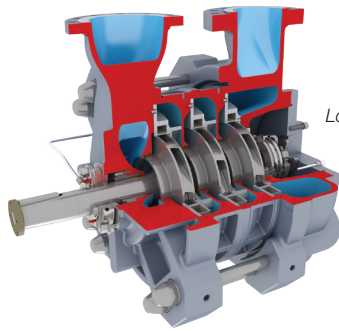

CSX
*Long-term, high efficiency
and low lifecycle cost*

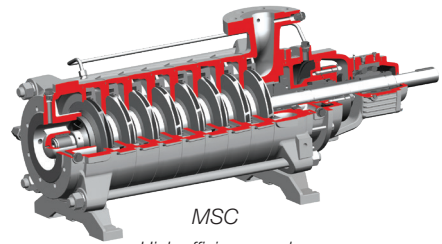

MSC
*High efficiency and
long-term reliability*

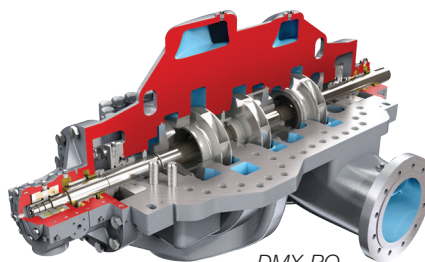

DMX-RO
*Increased uptime and
easy maintenance*

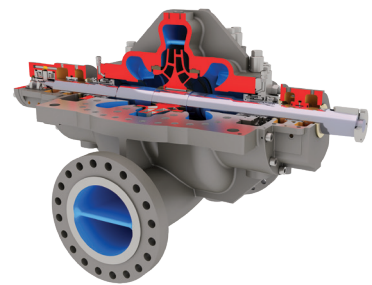

DVSH-RO
*Low operating cost
and increased reliability*

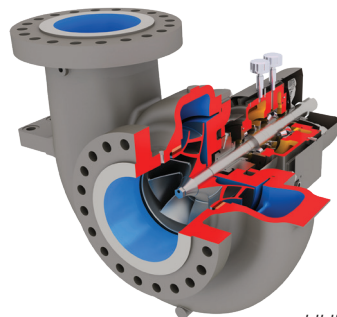

HHPX
*Reliable performance
under high pressure*

ERD boosters

Flowserve high-pressure booster pumps are designed to operate efficiently under SWRO system pressure, where design pressures can exceed 82 bar (1,200 psi). Horizontal and vertical inline designs are available for these tough applications.

Configurations: High suction pressure, end suction designs

Materials: Super duplex stainless steels

Models: HPX-H, HHPX

Flows: to 4,000 m³/h (17,611 gpm)

Heads: to 90 m (295 ft)

Customer testimonial

“Flowserve successfully installed and commissioned 10 units (30 DWEERs in total) of Energy Recovery System (ERS) at the 30 MIGD SingSpring desalination plant at Tuas, Singapore. The ERS units met the design specification and to date have operated very successfully within the design parameters. We appreciate the reliable performance of the DWEER products and the support provided by Flowserve throughout all these years.”

— Senior General Manager, Hyflux Engineering Pte Ltd.

Energy recovery devices for SWRO

Isobaric energy recovery device: DWEER

The DWEER system can recover up to 98% of the energy in the brine waste stream, making it the most efficient energy recovery device ever developed. Recovered energy is used to pressurize raw water, reducing the energy input you need for high-pressure feed pumps by 60%.

DWEER 1200 – Pressure: to 76 bar (1,100 psi)

DWEER 1550 – Pressure: to 82 bar (1,200 psi)



Energy recovery turbine impact machine

Energy recovery turbines are available in 50 and 60 Hz models for global applications. Flowserve can also manufacture custom-engineered products for applications outside this operating range. Seven standard models and diverse configurations are available.

Flows: to 1,200 m³/h (5,280 gpm)

Efficiency: to 90%

Pressures: to 80 bar (1,160 psi)



Mechanical seals for SWRO

Flowserve seals give your operation a competitive edge by extending the MTBF of critical rotating equipment. This advantage is made possible by industry-leading expertise in metallurgy and sophisticated mechanical sealing technologies designed to meet the challenges of SWRO.

Construction materials for mechanical seals used in SWRO applications include:

- Metal components:
 - Stainless steel for general water service
 - Flowserve Alloy for seawater, brine and chlorides
 - Super duplex is also available when specified
- Metal bellows:
 - Flowserve Alloy for all services
- Seal faces:
 - Carbon vs. silicon carbide for clean services
 - Silicon carbide vs. silicon carbide for services with solids or abrasives
 - Optional diamond coatings extend seal life

Plan 11 bypass flush from pump discharge is usually recommended. Additional cooling may be required for higher water temperatures.

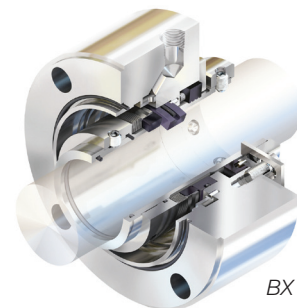
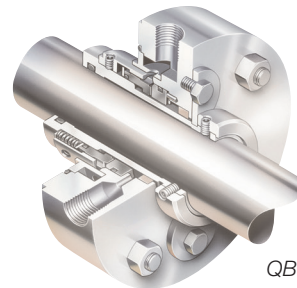
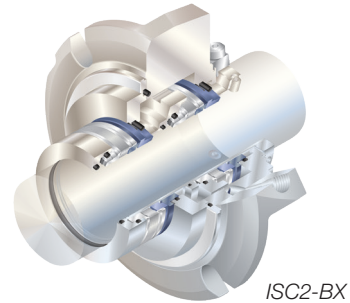
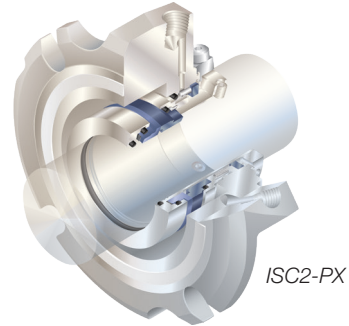

Valves for SWRO

Desalination processes, particularly SWRO systems, require numerous valves capable of handling large volumes of water at high pressures. These valves must also be made of materials capable of resisting corrosion from chloride-rich water and commonly used chemicals. Flowserve offers a complete range of valves and actuators to suit diverse desalination applications.

- Butterfly Valves
 - Lined
 - Triple-offset
- Ball Valves
 - Lined
 - Sleeve lined
 - Floating
- Plug Valves
 - Lubricated
 - Non-lubricated
 - Lined
- Check Valves
 - Tilting disk
- Service Control Valves
 - Linear globe/angle

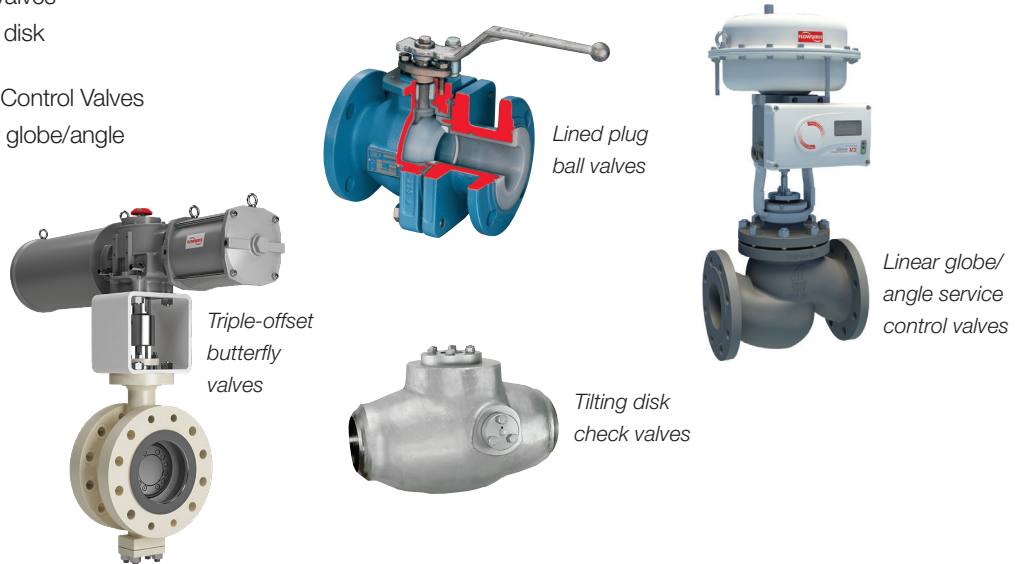

Actuators for SWRO

Whether you need fail-safe action, high-torque power or high-speed functionality, Flowserve actuators are built for the world's toughest jobs. Reliable operation, reduced maintenance and longer service life are made possible by the simplicity, efficiency and flexibility built into every design.

- Actuators
 - Electric
 - Pneumatic
- Positioners
 - Digital
 - Analog
- Switch Boxes



Pump models and ERDs application guide

Application		RO MEMBRANE										
		Intake	Filter Feed	UF Filter Feed	UF Cleaning	Low-Pressure Booster	ERD Booster	Energy Recovery	First Pass Membrane Feed	Second Pass Membrane Feed	Treated Water	DAF Pressurization
Vertical, wet and dry pit	VTP	X										
	VCT	X										
	SUBM	X										
Between bearings, single-stage	LNN		X			X					X	
	LNNV	X										
	DVSH							X				
Between bearings, multistage	DMX-RO							X				
	CSX							X				
	MSC							X				
	WDX							X				
Overhung, API process	HPX					X			X			
	HPX-H						X					
	HHPX						X					
Overhung, chemical or industrial	Mark 3		X		X							X
	DS		X			X				X		
	ZLN		X		X							X
	CBT		X		X							X
Energy recovery devices	DWEER							X				
	ERT							X				

How Flowserve benefits your desalination operation

Ethical business practices

Flowserve adheres to the highest standards of business integrity in all its dealings, both with you and our suppliers. You get a trustworthy partner committed to working toward your project's success.

Quality products and service

When you choose Flowserve, we'll strive to deliver complete satisfaction, including on-time commissioning and project startup. All equipment is manufactured to the most rigorous quality standards to ensure lifetime reliability.

Engineering excellence

Reliable operation will be ensured by product and material selection optimized for your specific application. You'll also benefit from a level of deep engineering experience unmatched in SWRO desalination.

Experience

Flowserve has been a leader in desalination since the process was commercialized on a large scale. Lessons learned over the course of more than a half-century have been built into today's products — increasing their reliability, maintainability and product life.

Broad product range

The Flowserve family includes numerous world-renowned heritage brands and a wide portfolio of products and services. Every Flowserve product is designed by leading specialists in their respective fields. The result is low-cost, high-efficiency solutions, from intake to distribution and energy recovery.

Project management

A dedicated, professional, IPMA-certified project management team will handle all documentation and ensure on-time delivery.

After-sales support

Your operation will be supported by dedicated engineers whose sole objective is to resolve warranty issues quickly and efficiently.

Local Quick Response Centers

A skilled local team can handle your upgrades and repairs from a fully equipped Quick Response Center in your region. Localized to reduce downtime, your team will have full access to all the Flowserve component drawings, procedures and standards needed to keep your operation up and running.

Aftermarket solutions

Long-term maintenance is available from a specialized group capable of maintaining, servicing and upgrading equipment to ensure you meet your operating and throughput goals.

Meeting your toughest desalination challenges

Expertise and Experience	<ul style="list-style-type: none"> • Flowserve has more than 30 years of experience in desalination • More than two out of three mega SWRO projects have Flowserve pumps and/or ERDs • Specialist “Center of Excellence” focusing on desalination
Single-Source Provider	<ul style="list-style-type: none"> • Optimizing equipment selections from early stage • Optimized overall efficiency of interacting products—pumps and ERDs • Specialist Desalination Center of Excellence • Less time evaluating • Reduced procurement activities
Streamlined Execution	<ul style="list-style-type: none"> • Global project management: <i>Single point of contact, flawless execution</i> • Simple communication and fast clarification channels • Reduced time to operation
Local Support	<ul style="list-style-type: none"> • Local support ensured through a global network of service centers • Support during installation and commissioning • Service and maintenance contracts for highest availability and continuous efficiency optimization • Support and repair ensured through local service centers • Upgrade opportunities through Desalination Center of Excellence • Full operation and service training
Optimizing Efficiency	<ul style="list-style-type: none"> • Highly efficient and reliable pump range for desalination • Reverse Osmosis Energy Recovery Device, DWEER, with highest efficiency plus low mixing and leakage • Continuous Improvement Program (CIP) specifically for desalination • Optimized high-pressure feed pumps • Optimized ERS booster pumps • Optimized DWEER Energy Recovery Device

Dedicated local support, worldwide



Support when and where you need it most

You'll never have to look far for support, thanks to a robust global network of manufacturing facilities, design centers of excellence, strategically located Quick Response Centers and on-site resources.

Aftermarket services that deliver results

Over the last few decades, ERD, pump and membrane technologies have improved. Overhauling existing equipment with new reliability features, more efficient hydraulics or other upgrades can deliver meaningful improvements in plant efficiency, production and availability while reducing maintenance.

Upgrade opportunities include:

Brine concentrator — Add a booster pump skid with high-salinity membranes to increase production capacity and lower specific energy consumption (SEC).

ERT replacement with DWEER — By replacing ERT energy recovery turbines with DWEER energy recovery devices, power consumption can be reduced and production capacity increased. The following options are available:

- Full retrofit
- Partial retrofit
- Cascade retrofit

Predicting equipment behavior

Traditional equipment monitoring methods — which rely on a find-and-fix approach — are not only outdated, but they're also inefficient and risky. These antiquated methods provide an incomplete view of your rotating equipment's health. Uncertainty leads to unplanned equipment downtime, which wrecks productivity, increases operating costs, and impacts your bottom line.

Asset health management solutions make it easy for you to monitor and predict rotating equipment behavior and take prompt actions when necessary to prevent unplanned downtime. With 24/7 insight into rotating equipment performance, you can focus on what really matters.



Flowserve Corporation
5215 North O'Connor Blvd.
Suite 2300
Irving, Texas 75039-5421 USA
Telephone: +1 937 890 5839

Flowserve Spain S.L.
Avenida Fuentemar 26/28.
28823 Coslada, Madrid, Spain
Telephone: +34 91 660 4600

Flowserve Corporation has established industry leadership in the design and manufacture of its products. When properly selected, this Flowserve product is designed to perform its intended function safely during its useful life. However, the purchaser or user of Flowserve products should be aware that Flowserve products might be used in numerous applications under a wide variety of industrial service conditions. Although Flowserve can provide general guidelines, it cannot provide specific data and warnings for all possible applications. The purchaser/user must therefore assume the ultimate responsibility for the proper sizing and selection, installation, operation, and maintenance of Flowserve products. The purchaser/user should read and understand the Installation Instructions included with the product, and train its employees and contractors in the safe use of Flowserve products in connection with the specific application.

While the information and specifications contained in this literature are believed to be accurate, they are supplied for informative purposes only and should not be considered certified or as a guarantee of satisfactory results by reliance thereon. Nothing contained herein is to be construed as a warranty or guarantee, express or implied, regarding any matter with respect to this product. Because Flowserve is continually improving and upgrading its product design, the specifications, dimensions and information contained herein are subject to change without notice. Should any question arise concerning these provisions, the purchaser/user should contact Flowserve Corporation at any one of its worldwide operations or offices.

©2020 Flowserve Corporation. All rights reserved. This document contains registered and unregistered trademarks of Flowserve Corporation. Other company, product, or service names may be trademarks or service marks of their respective companies.

MULTIBR000155-12 (EN/A4) November 2020