

# AGS Double Eccentric Butterfly Valve Series W710



20.25



---

## 1.0 PRODUCT DESCRIPTION

---

### Available Sizes

- 14 – 24"/DN350 – DN600

### Pipe Material

- Carbon Steel

### Pressure Class

- 232 psi/1600 kPa

### Operating Temperature

- +14°F to +176°F/-10°C to +80°C

### Function

- Used to isolate or regulate flow. Typically used on water services.
- Valve is designed for pressures ranging from full vacuum to 232psi/1600kPa and for bi-directional, dead end services to full working pressure.

### Pipe Preparation

- Exclusively for use with pipe and Victaulic products which feature ends formed with the Advanced Groove System (AGS), Cut Groove or Roll Groove (see section 7.0 for Reference Materials).

---

## 2.0 CERTIFICATION/LISTINGS

---

- Valve design, materials and testing conform to requirements of EN593 and EN12266.
- Product designed and manufactured under Victaulic's Quality Management System, as certified by LPCB in accordance with ISO 9001:2015.

ALWAYS REFER TO ANY NOTIFICATIONS AT THE END OF THIS DOCUMENT REGARDING PRODUCT INSTALLATION, MAINTENANCE OR SUPPORT.



### 3.0 SPECIFICATIONS – MATERIAL

---

**Body:** Ductile iron conforming to ASTM A536, grade 65-45-12, fusion bonded epoxy coated.

**Disc:** Ductile iron conforming to ASTM A536, grade 65-45-12, fusion bonded epoxy coated.

**Disc/Seal: EPDM**

Temperature range +14°F to +176°F/-10°C to +80°C. Recommended for cold and hot water service within the specified temperature range. NOT RECOMMENDED FOR PETROLEUM SERVICES.

**Bearing:** Aluminum bronze

**Stem Seals:** EPDM

**Seal Retaining Screw:** Stainless Steel conforming to ASTM A276, Type 304

**Shaft:** Stainless Steel conforming to ASTM A276, Type 420

**Body Seal:** Stainless Steel conforming to ASTM A276, Type 304

**Retainer:** Stainless Steel conforming to ASTM A276, Type 304

**O-Ring:** EPDM

**Bolt:** Stainless Steel conforming to ASTM A276, Type 304

## 4.0 DIMENSIONS

### Series W710

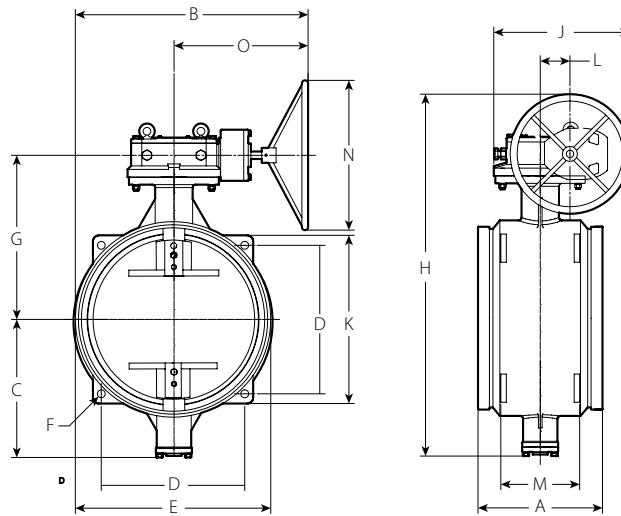

Size			Dimensions															Weight
Nominal	Actual Outside Diameter	Pressure	A End to End	B	C	D	E	F	G	H	J	K	L	M	N	O	Approx. (Each)	
inches DN	inches mm	psi kPa	inches mm	inches mm	inches mm	inches mm	inches mm	inches mm	inches mm	inches mm	inches mm	inches mm	inches mm	inches mm	inches mm	inches mm	lb kg	
14 DN350	14.000	232	11.50	18.88	11.50	11.50	15.13	0.88	14.00	33.50	16.13	13.00	4.00	5.63	15.75	11.38	213.0	
	356.0	1600	291	479	293	290	383	21	356	850	409	330	101	140	401	288	96.6	
	14.843	232	11.50	18.88	11.50	11.50	15.13	0.88	14.00	33.50	16.13	13.50	4.00	6.38	15.75	11.38	216.0	
	377.0	1600	291	479	293	290	383	21	356	850	409	340	101	161	401	288	98.0	
16 DN400	16.000	232	12.25	23.63	12.88	13.50	17.13	0.88	15.38	38.00	22.13	15.38	6.13	6.00	19.75	15.13	326.0	
	406.4	1600	310	599	326	340	434	21	390	965	561	390	153	151	501	383	147.9	
	16.772	232	12.25	23.63	12.88	13.00	17.13	0.88	15.38	38.00	22.13	15.38	6.13	6.75	19.75	15.25	330.0	
	426.0	1600	310	599	326	330	434	21	390	965	561	390	153	170	502	385	149.7	
18 DN450	18.000	232	13.00	27.25	14.00	14.63	19.13	0.88	17.38	41.38	19.75	17.13	2.00	6.38	19.75	17.75	440.0	
	457.2	1600	330	691	356	370	484	21	440	1050	500	435	50	161	501	449	199.6	
	18.898	232	13.00	27.25	14.00	14.63	19.13	0.88	17.38	41.38	19.75	17.13	2.00	7.13	19.75	17.75	444.0	
	480.0	1600	330	691	356	370	484	21	440	1050	500	435	50	181	501	449	201.4	
20 DN500	20.000	232	13.88	28.25	15.50	16.25	21.25	0.88	19.13	44.50	19.75	19.00	2.00	7.13	19.75	17.75	539.0	
	508.0	1600	351	717	394	410	538	21	486	1130	500	480	50	181	501	449	244.5	
	20.866	232	13.88	28.25	15.50	16.25	21.25	0.88	19.13	44.50	19.75	19.00	2.00	7.13	19.75	17.75	542.0	
	530.0	1600	351	717	394	410	538	21	486	1130	500	480	50	181	501	449	245.8	
24 DN600	24.000	232	15.38	30.25	18.00	19.00	25.13	1.00	21.63	49.50	19.75	22.13	2.00	9.13	19.75	17.75	722.0	
	609.6	1600	390	766	458	480	637	24	548	1255	500	560	50	231	501	449	327.5	
	24.803	232	15.38	30.25	18.00	19.00	25.13	1.00	21.63	49.50	19.75	22.13	2.00	9.13	19.75	17.75	725.0	
	630.0	1600	390	766	458	480	637	24	548	1255	500	560	50	231	501	449	328.9	

## 5.0 PERFORMANCE

### Series W710

Cv/Kv values for flow of water at +60°F/+16°C with various disc positions are shown in the table below.

Formulas for Cv/Kv values:

$$\Delta P = \frac{Q^2}{C_v^2}$$

$$Q = C_v \times \sqrt{\Delta P}$$

**Where:**

Q = Flow (GPM)

ΔP = Pressure Drop (psi)

C<sub>v</sub> = Flow Coefficient

$$\Delta P = \frac{Q^2}{K_v^2}$$







$$Q = K_v \times \sqrt{\Delta P}$$

**Where:**

Q = Flow (m<sup>3</sup>/hr)

ΔP = Pressure Drop (Bar)

K<sub>v</sub> = Flow Coefficient

Size		Flow Coefficients – Cv/Kv Disc Position (Degree Open)						
Nominal inches DN	Actual Outside Diameter inches mm	90 (full open) 	80 	70 	60 	50 	40 	30 
		Cv Kv	Cv Kv	Cv Kv	Cv Kv	Cv Kv	Cv Kv	Cv Kv
14 DN350	14.000	9112	7440	5494	3384	2178	1398	879
	356.0	7882	6436	4752	2927	1884	1209	760
	14.843	9613	7849	5789	3566	2295	1473	926
	377.0	8315	6789	5007	3085	1985	1274	801
16 DN400	16.000	11901	9718	7176	4420	2845	1826	1148
	406.4	10294	8406	6207	3823	2461	1579	993
	16.772	12402	10126	7468	4600	2960	1900	1194
	426.0	10728	8759	6460	3979	2560	1644	1033
18 DN450	18.000	15062	12298	9082	5594	3600	2311	1453
	457.2	13029	10638	7856	4839	3114	1999	1257
	18.898	16116	13159	9704	5978	3847	2469	1552
	480.0	13940	11383	8394	5171	3328	2136	1342
20 DN500	20.000	18595	15184	11231	6906	4445	2853	1793
	508.0	16085	13134	9715	5974	3845	2468	1551
	20.866	19524	15941	11757	7242	4660	2991	1880
	530.0	16888	13789	10170	6264	4031	2587	1626
24 DN600	24.000	29938	22835	16147	9945	6401	4107	2582
	609.6	25896	19752	13967	8602	5537	3553	2233
	24.803	31343	25591	18874	11626	7481	4802	3018
	630.0	27112	22136	16326	10056	6471	4154	2611

## 5.0 PERFORMANCE (CONTINUED)

### Torque Values

Size		Breakaway Torque with Valve Seat Downstream of Pressure (in. lb./N.m.)					
Nominal inches DN	Actual Outside Diameter inches mm	Differential Pressure					
		0 psi	50 psi	100 psi	150 psi	200 psi	232 psi
14 DN350	14.000	1204	4045	5452	7266	9063	10037
	356.0	136	457	616	821	1024	1134
	14.843	1204	4045	5452	7266	9063	10037
	377.0	136	457	616	821	1024	1134
16 DN400	16.000	1876	6691	9709	12949	16188	17994
	406.4	212	756	1097	1463	1829	2033
	16.772	1876	6691	9709	12949	16188	17994
	426.0	212	756	1097	1463	1829	2033
18 DN450	18.000	3062	8585	12276	16215	20251	22490
	457.2	346	970	1387	1832	2288	2541
	18.898	3062	8585	12276	16215	20251	22490
	480.0	346	970	1387	1832	2288	2541
20 DN500	20.000	3523	10683	15268	20357	25402	28216
	508.0	398	1207	1725	2300	2870	3188
	20.866	3523	10683	15268	20357	25402	28216
	530.0	398	1207	1725	2300	2870	3188
24 DN600	24.000	6709	20543	30615	40820	52131	61336
	609.6	758	2321	3459	4612	5890	6930
	24.803	6709	20543	30615	40820	52131	61336
	630.0	758	2321	3459	4612	5890	6930

Size		Breakaway Torque with Valve Seat Upstream of Pressure (in. lb./N.m.)					
Nominal inches DN	Actual Outside Diameter inches mm	Differential Pressure					
		0 psi	50 psi	100 psi	150 psi	200 psi	232 psi
14 DN350	14.000	841	3231	4089	5160	6249	6727
	356.0	95	365	462	583	706	760
	14.843	841	3231	4089	5160	6249	6727
	377.0	95	365	462	583	706	760
16 DN400	16.000	1221	5355	7248	9196	11170	12055
	406.4	138	605	819	1039	1262	1362
	16.772	1221	5355	7248	9196	11170	12055
	426.0	138	605	819	1039	1262	1362
18 DN450	18.000	1832	6868	9205	11506	13975	15073
	457.2	207	776	1040	1300	1579	1703
	18.898	1832	6868	9205	11506	13975	15073
	480.0	207	776	1040	1300	1579	1703
20 DN500	20.000	2673	8550	11453	14453	17524	18905
	508.0	302	966	1294	1633	1980	2136
	20.866	2673	8550	11453	14453	17524	18905
	530.0	302	966	1294	1633	1980	2136
24 DN600	24.000	5744	16436	23570	30615	39103	46095
	609.6	649	1857	2663	3459	4418	5208
	24.803	5744	16436	23570	30615	39103	46095
	630.0	649	1857	2663	3459	4418	5208

**NOTE**

- The torque values shown shall be used for sizing actuators on valves with a bare stem

### Valve Torque Requirements

**Source:**

These torque values were derived from test data with non-lubricated valves in water at ambient temperatures with EPDM seals. For other material and service conditions, apply a suitable service factor.

**Torque Factors:**

All torque values are for normal conditions (i.e., the valve is operated at least once a quarter, disc corrosion is expected to be minor, the media is clean and nonabrasive, and the chemical effects upon the elastomer are minor).

**Typical Fluid Torque Factors Commonly Used in the Industry:**

Water: 1.0

**Material Torque Factors:**

“E” = 1.0

**Cycling Factor:**

Torque will typically increase as the valve is cycled. A factor of 1.5 should be applied for the first 5,000 cycles and another 1.5 applied for all additional cycles. The higher number should be used if there is more than one cycle per hour.

**Actuation Factor:**

There are no actuation safety factors applied. A factor consistent with the consequences of not actuating should be applied. A minimum factor of 1.2 is recommended for directly actuated valves and 1.5 for 3-way assemblies.

- Contact Victaulic for other services.

## 5.0 PERFORMANCE (CONTINUED)

### Combining Torque Factors:

When multiple torque factors apply, they are combined by multiplying them. Example: For an EPDM seal and a 5,000-cycle factor, the combined factor would be  $1.0 \times (1.5) = 1.5$ .

#### NOTES

- Under certain high flow conditions, the hydrodynamic torque can exceed the seating torque. Large butterfly valves are not recommended for use in a free discharge condition, such as filling an empty line with fluid at the full-rated pressure.

## 6.0 NOTIFICATIONS

### ⚠ WARNING



- Read and understand all instructions before attempting to install, remove, adjust, or maintain any Victaulic piping products.
- Depressurize and drain the piping system before attempting to install, remove, adjust, or maintain any Victaulic piping products.
- Wear safety glasses, hardhat, and foot protection.

Failure to follow these instructions could result in death or serious personal injury and property damage.

### NOTICE

- DO NOT install valves with the disc in the full-open position. Make sure no part of the disc protrudes beyond the end of the valve body.
- Use ONLY grooved-end, NPS carbon steel pipe with Victaulic Butterfly Valves. DO NOT use plain-end NPS pipe or grooved cast ductile iron pipe.
- To prevent valves from rotating in the system, Victaulic recommends installing butterfly valves with at least one Victaulic rigid coupling. If two Victaulic flexible couplings are used, additional support may be required to prevent the valve from rotating. Refer to the instructions, supplied with the couplings and butterfly valves, for proper installation.

## 7.0 REFERENCE MATERIALS

[16.11: AGS Vic-Ring® Systems](#)

[20.02: AGS Rigid Coupling](#)

[20.05: AGS Fittings](#)

[25.09: AGS Roll Groove Data](#)

[26.01: Victaulic Design Data](#)

[I-100: Victaulic Field Installation Handbook](#)

[I-W100: Victaulic AGS Field Installation Hand Book](#)

#### User Responsibility for Product Selection and Suitability

Each user bears final responsibility for making a determination as to the suitability of Victaulic products for a particular end-use application, in accordance with industry standards and project specifications, and the applicable building codes and related regulations as well as Victaulic performance, maintenance, safety, and warning instructions. Nothing in this or any other document, nor any verbal recommendation, advice, or opinion from any Victaulic employee, shall be deemed to alter, vary, supersede, or waive any provision of Victaulic Company's standard conditions of sale, installation guide, or this disclaimer.

#### Intellectual Property Rights

No statement contained herein concerning a possible or suggested use of any material, product, service, or design is intended, or should be construed, to grant any license under any patent or other intellectual property right of Victaulic or any of its subsidiaries or affiliates covering such use or design, or as a recommendation for the use of such material, product, service, or design in the infringement of any patent or other intellectual property right. The terms "Patented" or "Patent Pending" refer to design or utility patents or patent applications for articles and/or methods of use in the United States and/or other countries.

#### Note

This product shall be manufactured by Victaulic or to Victaulic specifications. All products to be installed in accordance with current Victaulic installation/assembly instructions. Victaulic reserves the right to change product specifications, designs and standard equipment without notice and without incurring obligations.

#### Installation

Reference should always be made to the Victaulic installation handbook or installation instructions of the product you are installing. Handbooks are included with each shipment of Victaulic products, providing complete installation and assembly data, and are available in PDF format on our website at [www.victaulic.com](http://www.victaulic.com).

#### Warranty

Refer to the Warranty section of the current Price List or contact Victaulic for details.

#### Trademarks

*Victaulic* and all other Victaulic marks are the trademarks or registered trademarks of Victaulic Company, and/or its affiliated entities, in the U.S. and/or other countries.